

PLATFORM BRIEF

Intel® Core™ Processors with
Mobile Intel® QM87 and Mobile
Intel® HM86 Chipsets
Intelligent Systems



4th Generation Intel® Core™ Processor-Based Platforms for Intelligent Systems (i7-4700EQ, i5-4400E, i5-4402E, i3-4100E, and i3-4102E)

Ideal for Intelligent Systems—context-aware, securely managed embedded devices that connect seamlessly to networks, clouds and each other.



Product Overview

Manufactured on industry-leading 22nm process technology with 3D Tri-Gate transistors, these 4th generation Intel® Core™ processors provide superior CPU, graphics and media performance. Along with flexibility and enhanced security, they are ideal for a wide range of intelligent systems, including retail transaction terminals, digital signage, digital security and surveillance, gaming, industrial automation, and medical equipment.

These 4th generation Intel Core processors offer numerous advancements over 3rd generation Intel® Core™ processors. With the introduction of Intel® Advanced Vector Extensions (Intel® AVX) 2.0, they deliver improved integer/matrix-based calculation abilities, while upgrades to Intel® AES New Instructions¹ (Intel® AES-NI) allow security algorithms to benefit from hardware acceleration for data encryption and decryption.

Next-generation Intel® graphics engines significantly improve graphics and media performance. Platforms support up to three independent displays, enabling one system to drive multiple screens without the need for a discrete graphics card. Built-in visual features, including Intel® Clear Video HD technology and Intel® Quick Sync Video 2.0, deliver smoother visual quality, improved ability to decode and

transcode simultaneous video streams, and outstanding HD media playback. Additionally, the platform supports next-generation graphics APIs, such as Microsoft DirectX* 11.1, OpenGL* 4.0, and OpenCL* 1.2.

When paired with the Mobile Intel® QM87 or Mobile Intel® HM86 chipset, these platforms support dual-channel DDR3L memory at 1600 MHz (ECC optional) and Intel® Rapid Start Technology² for increased system responsiveness and fast recovery from sleep states. They support faster connectivity and flexibility with integrated next-generation I/O technologies such as PCI Express* Gen 2.0, SATA 6.0 Gbps, and USB 3.0 with Intel® Flex I/O.

Intel® vPro™ technology³ is enabled when select processor SKUs are paired with the Mobile Intel QM87 chipset. These platforms deliver intelligent security, supporting operating system-absent manageability, and down-the-wire security even when the system is powered off, the operating system is unresponsive, or software agents are disabled.

These processors offer quad-core capabilities with industry-leading performance and thermal design power (TDP) ranging from 47 W to 25 W. While incorporating advanced technology, they remain software-compatible with previous processors.

Platform Highlights

Intel® HD Graphics 4600: Supports enhanced high-end media and graphics capabilities and performance.

Intel® Quick Sync Video 2.0: Significantly improves decode and transcode performance and frees up the CPU for other tasks.

Intel® Advanced Vector Extensions 2.0: Accelerates integer/matrix compute performance for signal and image processing applications.

Intel® AES New Instructions¹ (Intel® AES-NI): Supports hardware acceleration for data encryption and decryption.

Intel® Intelligent Power Technology: Reduces idle power consumption through architectural improvements such as integrated power gates and automated low-power states.

Intel® Flex I/O: Allows user to assign four to six SATA 6.0 Gbps ports, six to eight PCI Express* Gen 2.0 ports and four to six USB 3.0 ports, based on configuration needs.

Error Correcting Code (ECC): Delivers a high level of data integrity, reliability and system uptime (optional).

Intel® Turbo Boost Technology⁴ 2.0: Runs applications faster by using available thermal headroom to run at a higher frequency.

Intel® Hyper-Threading Technology⁵: Simultaneous multi-threading helps boost performance for parallel, multi-threaded applications.

Intel® vPro™ Technology³: Delivers unprecedented hardware support for vital security and management functions with Intel® Active Management Technology,⁵ Intel® Virtualization Technology,⁷ and Intel® Trusted Execution Technology⁸ (select SKUs).

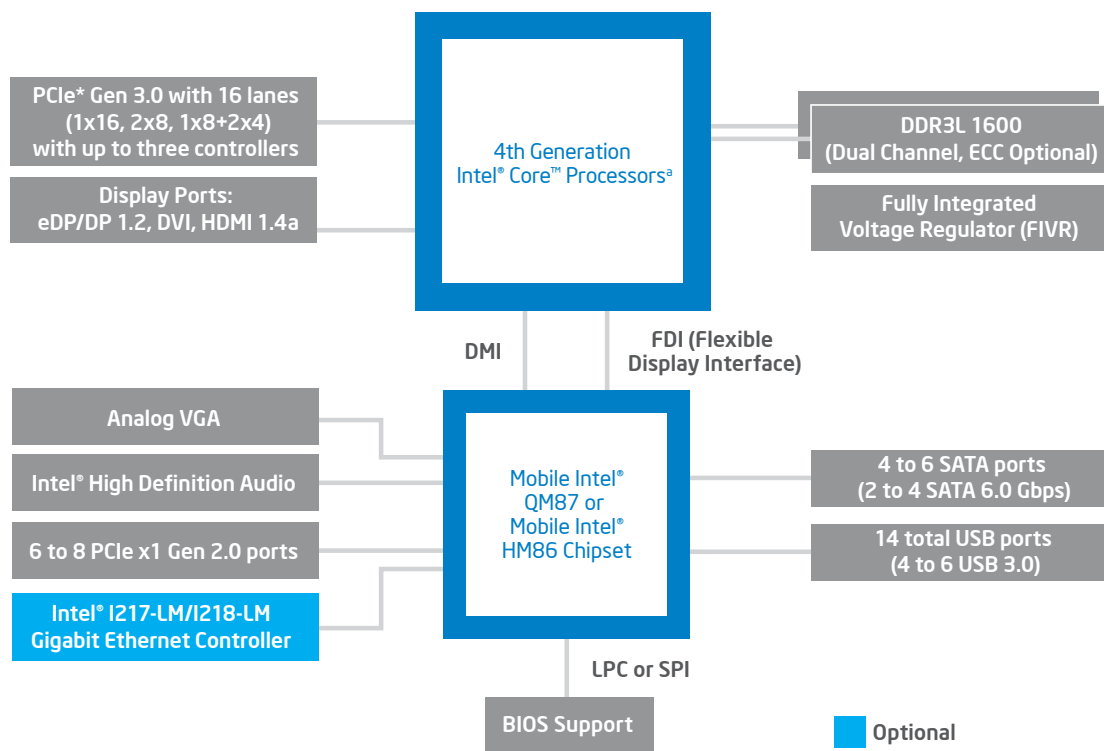

*I7-4700EQ, I5-4400E, I5-4402E, I3-4100E or I3-4102E

Software Overview

The following independent operating system and BIOS vendors provide support for these platforms.

OPERATING SYSTEM

Microsoft Windows* 8
 Microsoft Windows Embedded Standard 8
 Microsoft Windows 7
 Microsoft Windows Embedded Standard 7
 Microsoft Windows XP SP3^b
 Microsoft Windows Embedded Standard 2009^b
 Microsoft Windows POS 2009^b
 Linux* (Kernel 3.x)
 Wind River VxWorks* 6.9
 SUSE SLE* 11 SP1

CONTACT

Intel provides drivers⁹
 Intel provides drivers⁹
 Intel provides drivers⁹
 Intel provides drivers⁹
 Intel provides drivers⁹
 Intel provides drivers⁹
 Intel provides drivers⁹
 Wind River, Red Hat, Novell
 Wind River
 Novell

BIOS

American Megatrends
 Insyde Software
 Phoenix Technologies
 Byosoft

^bNot all features are supported. Contact your local Intel representative for more information.

4th Generation Intel® Core™ Processor-Based Platforms for Intelligent Systems

4th generation Intel® Core™ processors offer numerous advancements over 3rd generation Intel® Core™ processors.

FEATURES	BENEFITS
Key Embedded Support	
Extended life cycle product support	<ul style="list-style-type: none"> Protects system investment by enabling extended product availability for embedded customers.
Ecosystem support	<ul style="list-style-type: none"> From modular components to market-ready systems, Intel and the 250+ global member companies of the Intel® Intelligent Systems Alliance (intel.com/go/intelligentsystems-alliance) provide the performance, connectivity, manageability, and security developers need to create smart, connected systems.
Built-In Visuals	
Intel® HD Graphics 4600	<ul style="list-style-type: none"> Delivers enhanced visual experiences, including excellent 3D performance, the addition of HDMI 4K support, and enhanced color and deep color support for a broad range of intelligent systems. Provides repartitioned display architecture, allowing three independent displays and hybrid multi-monitor configurations. Integrated processor graphics help minimize power consumption while maximizing performance for decoding, encoding, and transcoding workloads with hardware acceleration of video codecs.
Intel® Quick Sync Video 2.0	<ul style="list-style-type: none"> Improved ability to decode and transcode simultaneous video streams for intelligent systems, including medical imaging and video surveillance functions.
Intel® Clear Video HD Technology	<ul style="list-style-type: none"> Provides visual quality and color fidelity enhancements for spectacular HD media playback for applications such as digital signs and gaming platforms.
Security	
Intel® AES New Instructions (Intel® AES-NI) ¹ and Intel® Secure Key ¹⁰	<ul style="list-style-type: none"> Helps protect media, data and assets from loss. Intel AES-NI accelerates data encryption/decryption and improves performance.
Intel® OS Guard	<ul style="list-style-type: none"> Helps detect and prevent malware.
Intel® Platform Protection Technology with BIOS Guard	<ul style="list-style-type: none"> Protects Flash from modification without platform manufacturer authorization.
Performance	
Intel® Advanced Vector Extensions 2.0	<ul style="list-style-type: none"> Supports faster performance on digital signal and image processing workloads of compute-intensive applications such as radar detection, hurricane command centers, ruggedized navigation systems and remote medical image processing.
Intel® Turbo Boost Technology ⁴ 2.0	<ul style="list-style-type: none"> Boosts performance for specific workloads by increasing processor frequency.
Intel® Hyper-Threading Technology ⁵	<ul style="list-style-type: none"> Enables simultaneous multi-threading within each processor core, up to two threads per core; reduces computational latency, making optimal use of every clock cycle.
Error Correcting Code (ECC) memory (Optional)	<ul style="list-style-type: none"> Detects multiple-bit memory errors; locates and corrects single-bit errors to keep the system up and running.
Intel® Smart Cache Technology	<ul style="list-style-type: none"> Large on-die shared Last-Level Cache reduces latency to data, improving performance and power efficiency.
Power Efficiency	
Intel® Intelligent Power Technology	<ul style="list-style-type: none"> Automated energy efficiency to reduce power consumption.
Automated low-power states	<ul style="list-style-type: none"> Adjusts system power consumption based on real-time processor loads.
Intel® Rapid Start Technology ²	<ul style="list-style-type: none"> Improves OS boot time and wakes up from deep sleep state more quickly than previous generations for better system responsiveness.
Fully Integrated Voltage Regulator	<ul style="list-style-type: none"> Simplifies power delivery by integrating legacy power delivery onto processor package/die.
Intel® vPro™ Technology³ (platforms paired with Mobile Intel® QM87 chipset)	
Intel® Active Management Technology 9.0 ⁶	<ul style="list-style-type: none"> 9.0 version of Intel's remote management and maintenance capabilities enables vendors to roll back firmware image; remote host capabilities help ease provisioning of end devices.
Intel® Virtualization Technology ⁷	<ul style="list-style-type: none"> Speeds transfer of platform control and movement of data between the virtual machine monitor (VMM) and other platform agents (including guest OSs and I/O devices). By lowering the workload on the VMM, this technology addresses many embedded system design challenges, like migrating legacy software, increasing real-time performance, and making applications more secure.
Intel® Trusted Execution Technology ⁸	<ul style="list-style-type: none"> Protects embedded devices and virtual environments against rootkit and other system-level attacks. Using an industry-standard TPM 1.2 to store keys and other protected data, this portion of Intel® vPro™ technology boots the BIOS, operating system, and software into a "trusted" execution state, verifying the integrity of the virtual machine and protecting the platform from unauthorized access.

4th Generation Intel® Core™ Processors for Intelligent Systems

PROCESSOR NUMBER ^A	CORE FREQUENCY (GHz)				THERMAL DESIGN POWER	PACKAGE	INTEL® AES-NI	INTEL® AVX
	CORES/ THREADS	BASE FREQUENCY	1 CORE TURBO (MAX)	INTEL® SMART CACHE				
Intel® Core™ i7-4700EQ Processor	4/8	2.4	3.4	6 MB	47 W/37 W	BGA1364	Yes	Yes
Intel® Core™ i5-4400E Processor	2/4	2.7	3.3	3 MB	37 W	BGA1364	Yes	Yes
Intel® Core™ i5-4402E Processor	2/4	1.6	2.7	3 MB	25 W	BGA1364	Yes	Yes
Intel® Core™ i3-4100E Processor	2/4	2.4	N/A	3 MB	37 W	BGA1364	No	Yes
Intel® Core™ i3-4102E Processor	2/4	1.6	N/A	3 MB	25 W	BGA1364	No	Yes

PROCESSOR NUMBER ^A	INTEL® vPRO™ TECHNOLOGY ^B					
	INTEL® TURBO BOOST TECHNOLOGY 2.0	INTEL® HYPER-THREADING TECHNOLOGY	INTEL® VIRTUALIZATION TECHNOLOGY	INTEL® ACTIVE MANAGEMENT TECHNOLOGY 9.0	INTEL® TRUSTED EXECUTION TECHNOLOGY	ERROR CORRECTING CODE
Intel® Core™ i7-4700EQ Processor	Yes	Yes	Yes	Yes	Yes	Optional
Intel® Core™ i5-4400E/i5-4402E Processors	Yes	Yes	Yes	Yes	Yes	Optional
Intel® Core™ i3-4100E/i3-4102E Processors	No	Yes	Yes	No	No	Optional

^AWhen paired with the Mobile Intel® QM87 chipset

Intel® Chipsets for Intelligent Systems

PRODUCT	PRODUCT CODE	PACKAGE	FEATURES
Intel® DH82QM87 Platform Controller Hub	DH82QM87	FCBGA 695	6 SATA ports (2 to 4 SATA 6.0 Gbps); 14 total USB ports (4 to 6 USB 3.0); 6 to 8 PCI Express* x1 Gen 2.0 ports; supports Intel® vPro™ Technology
Intel® DH82HM86 Platform Controller Hub	DH82HM86	FCBGA 695	4 SATA ports (2 SATA 6.0 Gbps); 14 total USB ports (2 to 4 USB 3.0); 6 to 8 PCI Express x1 Gen 2.0 ports

Intel in Intelligent Systems: intel.com/intelligentsystems

^A Intel processor numbers are not a measure of performance. Processor numbers differentiate features within each processor family, not across different processor families: Go to: http://www.intel.com/products/processor_number.

¹ Intel® AES-NI requires a computer system with an AES-NI enabled processor, as well as non-Intel software to execute the instructions in the correct sequence. AES-NI is available on select Intel® processors. For availability, consult your reseller or system manufacturer. For more information, see <http://software.intel.com/en-us/articles/intel-advanced-encryption-standard-instructions-aes-ni>.

² Requires a select Intel® processor, Intel® software and BIOS update, and Intel® Solid-State Drive (SSD). Depending on system configuration, your results may vary. Contact your system manufacturer for more information.

³ Intel® vPro™ Technology is sophisticated and requires setup and activation. Availability of features and results will depend upon the setup and configuration of your hardware, software and IT environment. To learn more visit: <http://www.intel.com/technology/vpro>.

⁴ Requires a system with Intel® Turbo Boost Technology. Intel Turbo Boost Technology and Intel Turbo Boost Technology 2.0 are only available on select Intel® processors. Consult your PC manufacturer. Performance varies depending on hardware, software, and system configuration. For more information, visit <http://www.intel.com/go/turbo>.

⁵ Requires an Intel® HT Technology-enabled system. Consult your PC manufacturer. Performance will vary depending on the specific hardware and software used. For more information including details on which processors support HT Technology, visit <http://www.intel.com/info/hyperthreading>.

⁶ Requires activation and a system with a corporate network connection, an Intel® AMT-enabled chipset, network hardware and software. For notebooks, Intel AMT may be unavailable or limited over a host OS-based VPN, when connecting wirelessly, on battery power, sleeping, hibernating or powered off. Results dependent upon hardware, setup and configuration. For more information, visit <http://www.intel.com/technology/platform-technology/intel-amt>.

⁷ Intel® Virtualization Technology requires a computer system with an enabled Intel® processor, BIOS, and virtual machine monitor (VMM). Functionality, performance or other benefits will vary depending on hardware and software configurations. Software applications may not be compatible with all operating systems. Consult your PC manufacturer. For more information, visit <http://www.intel.com/go/virtualization>.

⁸ No computer system can provide absolute security under all conditions. Intel® Trusted Execution Technology (Intel® TXT) requires a computer with Intel® Virtualization Technology, an Intel TXT-enabled processor, chipset, BIOS, Authenticated Code Modules and an Intel TXT-compatible measured launched environment (MLE). Intel TXT also requires the system to contain a TPM v1.s. For more information, visit <http://www.intel.com/technology/security>.

⁹ Drivers available at: downloadcenter.intel.com (enter chipset name).

¹⁰ No system can provide absolute security. Requires an Intel® Secure Key-enabled PC with a 3rd gen or 4th gen Intel® Core™ vPro™ processor and software optimized to support Intel Secure Key. Consult your system manufacturer for more information.

Performance results are based on certain tests measured on specific computer systems. Any difference in system hardware, software or configurations will affect actual performance. For more information go to <http://www.intel.com/performance>. INFORMATION IN THIS DOCUMENT IS PROVIDED IN CONNECTION WITH INTEL® PRODUCTS. NO LICENSE, EXPRESS OR IMPLIED, BY ESTOPPEL OR OTHERWISE, TO ANY INTELLECTUAL PROPERTY RIGHTS IS GRANTED BY THIS DOCUMENT. EXCEPT AS PROVIDED IN INTEL'S TERMS AND CONDITIONS OF SALE FOR SUCH PRODUCTS, INTEL ASSUMES NO LIABILITY WHATSOEVER, AND INTEL DISCLAIMS ANY EXPRESS OR IMPLIED WARRANTY, RELATING TO SALE AND/OR USE OF INTEL PRODUCTS INCLUDING LIABILITY OR WARRANTIES RELATING TO FITNESS FOR A PARTICULAR PURPOSE, MERCHANTABILITY, OR INFRINGEMENT OF ANY PATENT, COPYRIGHT OR OTHER INTELLECTUAL PROPERTY RIGHT. A "MISSION CRITICAL APPLICATION" IS ANY APPLICATION IN WHICH FAILURE OF THE INTEL PRODUCT COULD RESULT, DIRECTLY OR INDIRECTLY, IN PERSONAL INJURY OR DEATH. SHOULD YOU PURCHASE OR USE INTEL'S PRODUCTS FOR ANY SUCH MISSION CRITICAL APPLICATION, YOU SHALL INDEMNIFY AND HOLD INTEL AND ITS SUBSIDIARIES, SUBCONTRACTORS AND AFFILIATES, AND THE DIRECTORS, OFFICERS, AND EMPLOYEES OF EACH, HARMLESS AGAINST ALL CLAIMS COSTS, DAMAGES, AND EXPENSES AND REASONABLE ATTORNEYS' FEES ARISING OUT OF, DIRECTLY OR INDIRECTLY, ANY CLAIM OF PRODUCT LIABILITY, PERSONAL INJURY, OR DEATH ARISING IN ANY WAY OUT OF SUCH MISSION CRITICAL APPLICATION, WHETHER OR NOT INTEL OR ITS SUBCONTRACTOR WAS NEGLIGENT IN THE DESIGN, MANUFACTURE, OR WARNING OF THE INTEL PRODUCT OR ANY OF ITS PARTS.

Intel may make changes to specifications and product descriptions at any time, without notice. Designers must not rely on the absence or characteristics of any features or instructions marked "reserved" or "undefined." Intel reserves these for future definition and shall have no responsibility whatsoever for conflicts or incompatibilities arising from future changes to them. The information here is subject to change without notice. Do not finalize a design with this information.

The products described in this document may contain design defects or errors known as errata which may cause the product to deviate from published specifications. Current characterized errata are available on request. Contact your local Intel sales office or your distributor to obtain the latest specifications and before placing your product order. Copies of documents which have an order number and are referenced in this document, or other Intel literature, may be obtained by calling 1-800-548-4725, or by visiting Intel's Web site at www.intel.com.

Copyright © 2013 Intel Corporation. All rights reserved. Intel, the Intel logo, Core, and vPro are trademarks of Intel Corporation in the U.S. and other countries.

*Other names and brands may be claimed as the property of others.

Printed in USA

0813/KSC/OCG/PDF

 Please Recycle

328977-002US

